

REVISIONS			
REV. NO.	DESCRIPTION	DATE	EDN NO.

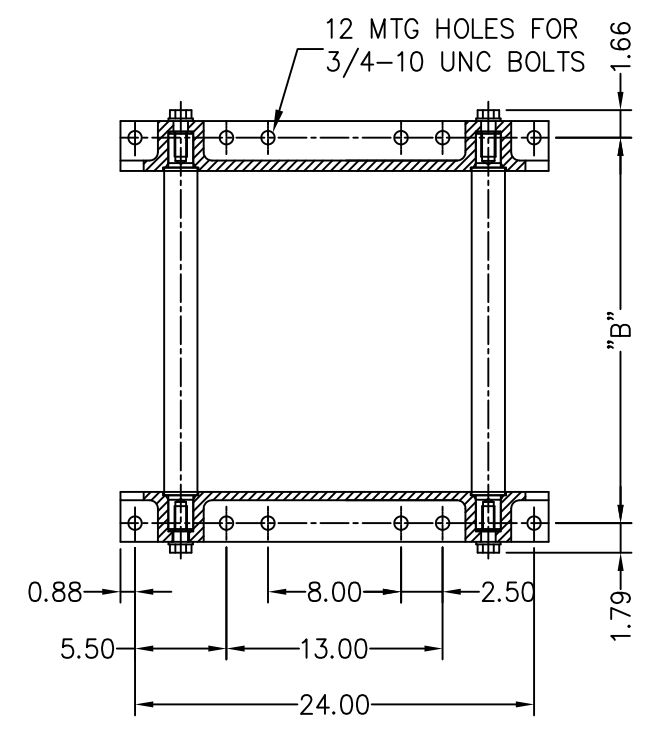

SECTION A-A

WINCH P/N	DIM "A"	DIM "B"	DIM "C"	WT w/o ROPE
HUR30/40/60ML-8	8.0	23.18	40.8	1088
HUR30/40/60ML-10	10.0	25.18	42.8	1115
HUR30/40/60ML-12	12.0	27.18	44.8	1142
HUR30/40/60ML-14	14.0	29.18	46.8	1169
HUR30/40/60ML-18	18.0	33.18	50.8	1223
HUR30/40/60ML-20	20.0	35.18	52.8	1250
HUR30/40/60ML-24	24.0	39.18	56.8	1304

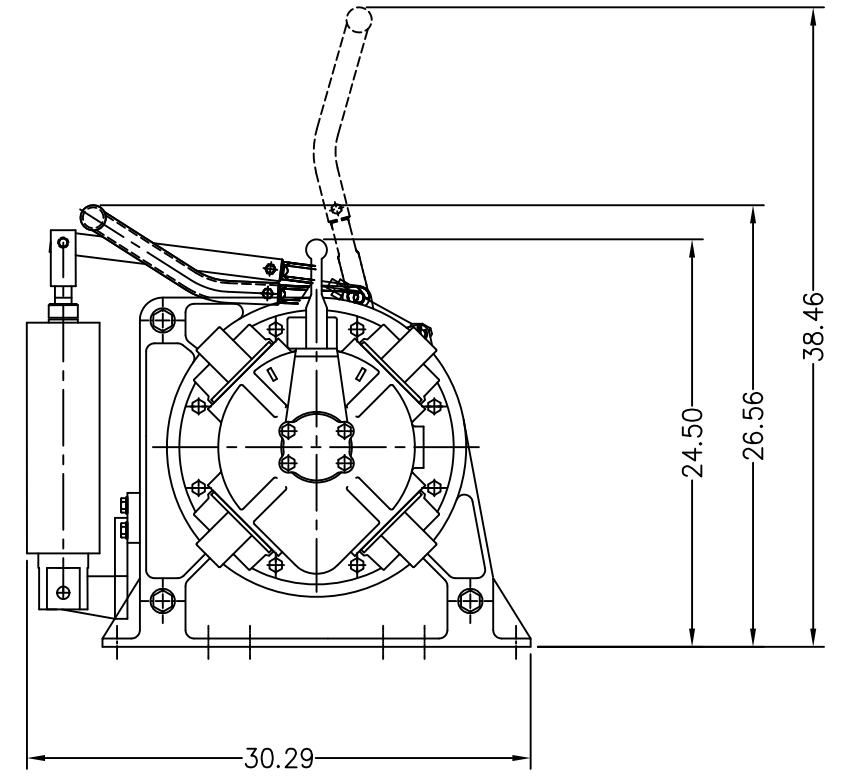
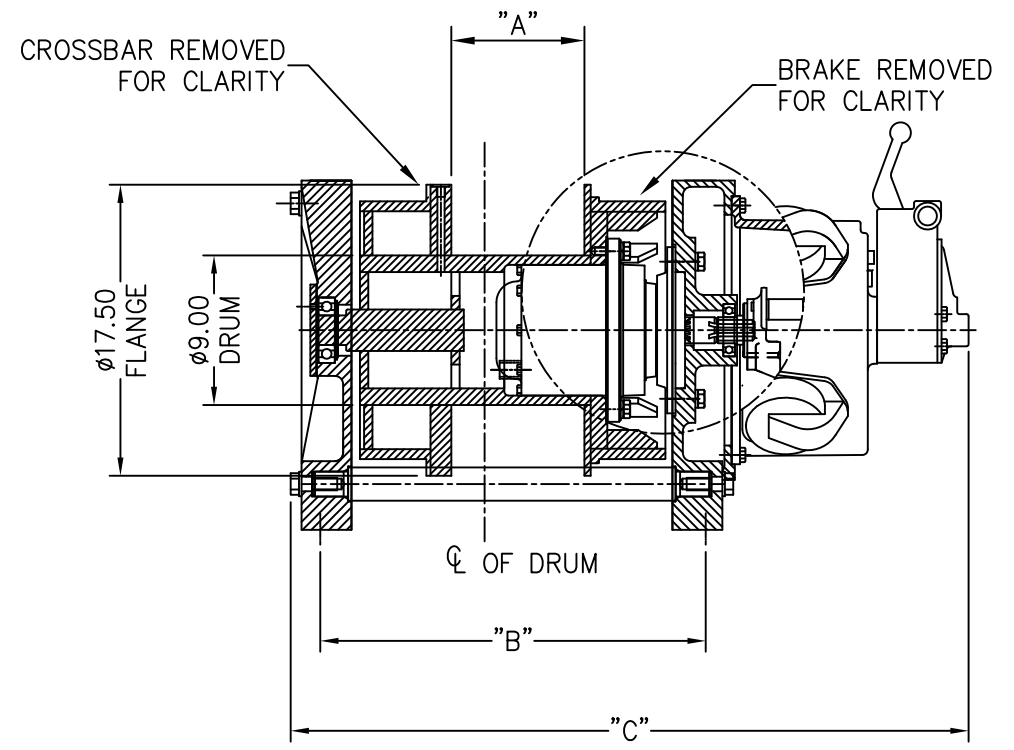
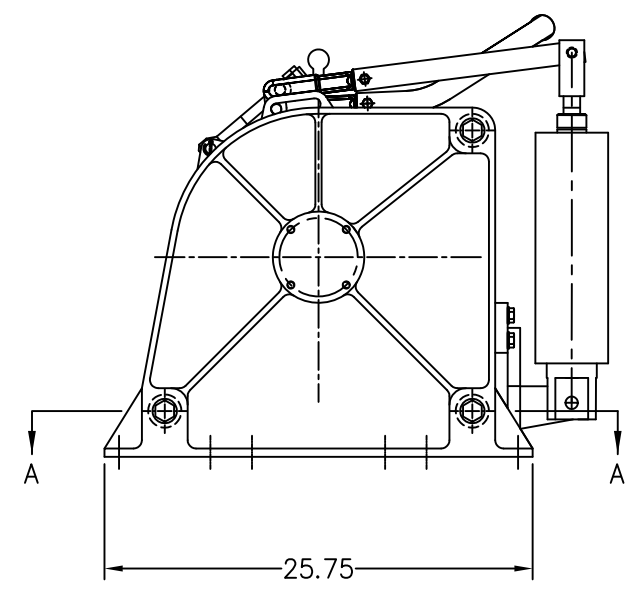

TOLERANCE UNLESS OTHERWISE SPECIFIED	PAIN'T SPEC.	DO NOT SCALE	
.XX ± .015	MATERIAL	DRAWN BY JNN	DATE
.XXX ± .005		CHECKED	DATE
FRACTION ± 1/16		APPROVED	DATE
ON ALL MACHINED SURFACES	UNLESS OTHERWISE SPECIFIED: ALL DIMENSIONS ARE IN INCHES REMOVE ALL SHARP CORNERS WITH .03R MAX.		

This drawing is the property of RAM ITC. The design and data shown includes proprietary information that describes RAM ITC products. The borrower by receipt and retention of the drawing agrees that except as expressly authorized in writing by RAM ITC, it will (1) only use the drawing or the design and data shown for the purpose intended by RAM ITC; (2) not loan, reproduce, exhibit or distribute the drawing or any copy or the design or data shown for use by other than RAM ITC, and (3) upon demand return the drawing, all copies and all material copies therefrom.

RAM WINCH
HOIST
P.O. BOX 62063
HOUSTON, TEXAS 77205

CUSTOMER:
CUSTOMER P.O. NO.:
PROJECT:

DRAWING TITLE:
WINCH GENERAL ASSEMBLY (R.H.)
MODEL:
HUR30/40/60ML w/AUTO & MAN. BRAKE
JOB NO.:
DRAWING NUMBER:
S001549
REV.: 1
DATE: 11/07/07
SIZE: B
SCALE: 1"=1'-0"